

74HC597; 74HCT597

8-bit shift register with input flip-flops

Rev. 4 — 25 February 2016

Product data sheet

1. General description

The 74HC597; 74HCT597 is an 8-bit shift register with input flip-flops. It consists of an 8-bit storage register feeding a parallel-in, serial-out 8-bit shift register. Both the storage register and the shift register have positive edge-triggered clocks. The shift register also has direct load (from storage) and clear inputs. Inputs include clamp diodes that enable the use of current limiting resistors to interface inputs to voltages in excess of V_{CC} .

2. Features and benefits

- Complies with JEDEC standard JESD7A
- Input levels:
 - ◆ For 74HC597: CMOS level
 - ◆ For 74HCT597: TTL level
- 8-bit parallel storage register inputs
- Shift register has direct overriding load and clear
- ESD protection:
 - ◆ HBM EIA/JESD22-A114F exceeds 2000 V
 - ◆ MM EIA/JESD22-A115-A exceeds 200 V
- Specified from -40 °C to $+85\text{ °C}$ and from -40 °C to $+125\text{ °C}$
- Multiple package options

3. Ordering information

Table 1. Ordering information

Type number	Package			
	Temperature range	Name	Description	Version
74HC597D	-40 °C to $+125\text{ °C}$	SO16	plastic small outline package; 16 leads; body width 3.9 mm	SOT109-1
74HCT597D				
74HC597DB	-40 °C to $+125\text{ °C}$	SSOP16	plastic shrink small outline package; 16 leads; body width 5.3 mm	SOT338-1
74HCT597DB				
74HC597PW	-40 °C to $+125\text{ °C}$	TSSOP16	plastic thin shrink small outline package; 16 leads; body width 4.4 mm	SOT403-1

4. Functional diagram

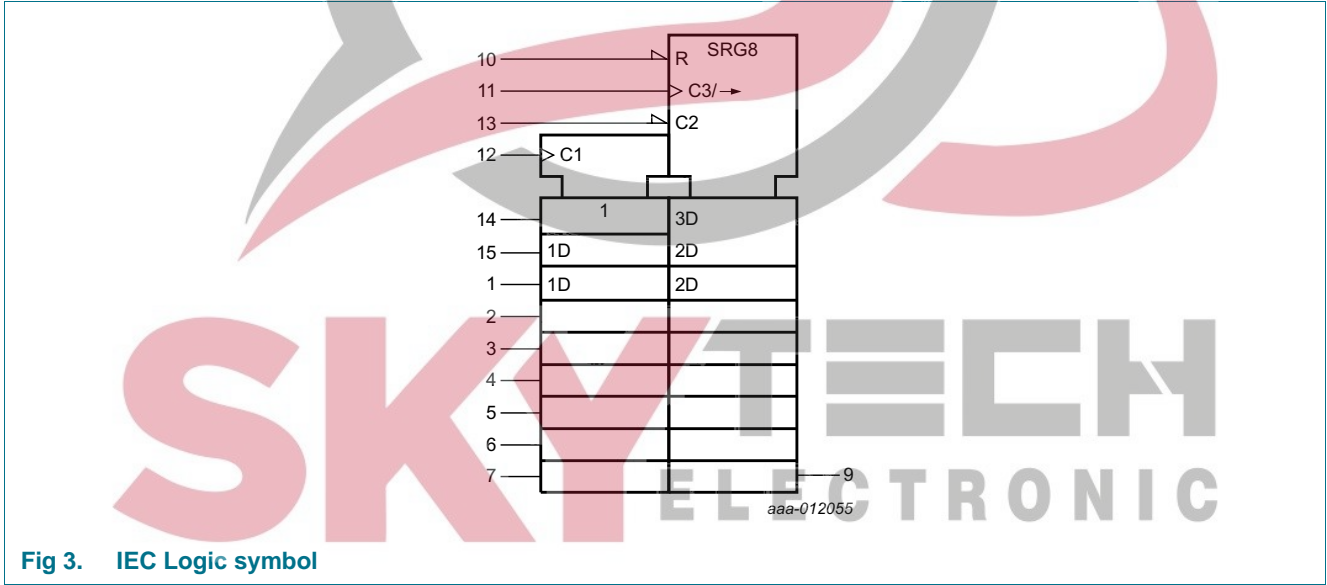
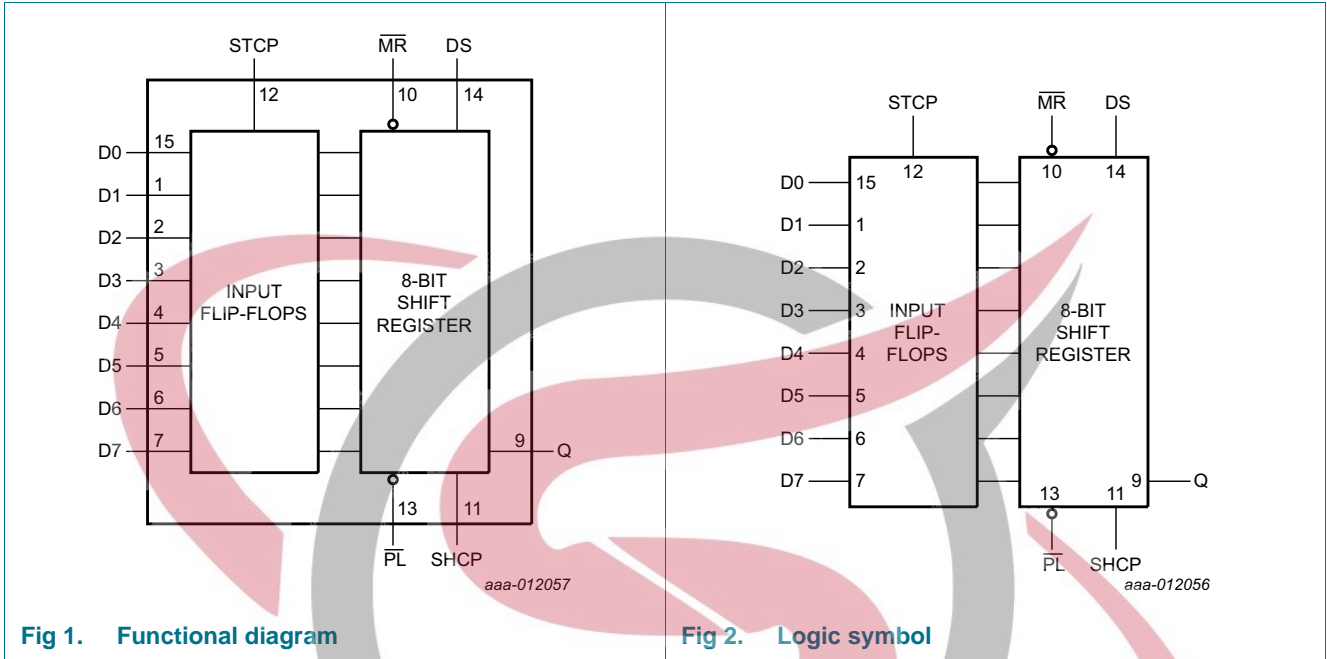

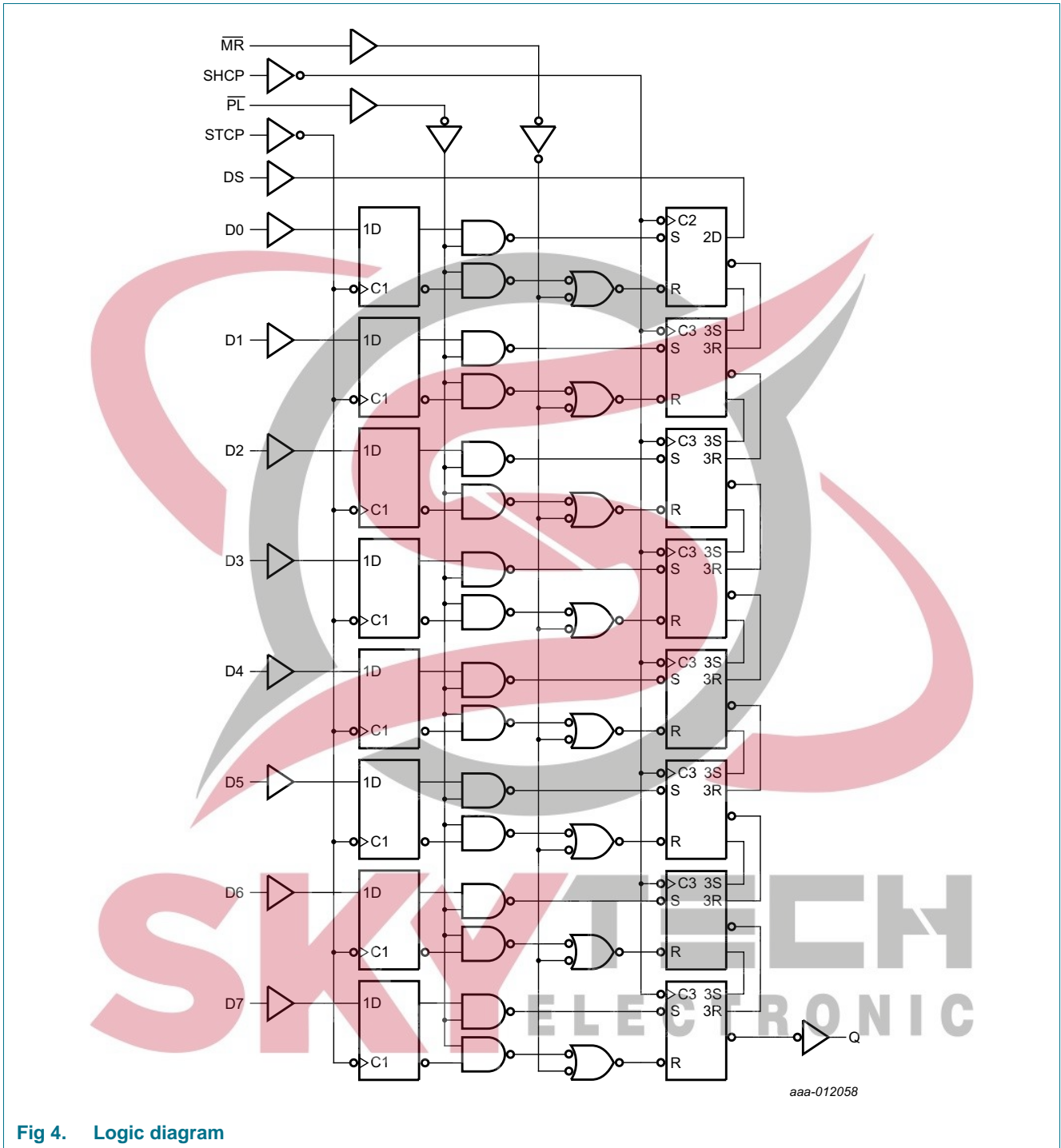

5. Pinning information

5.1 Pinning

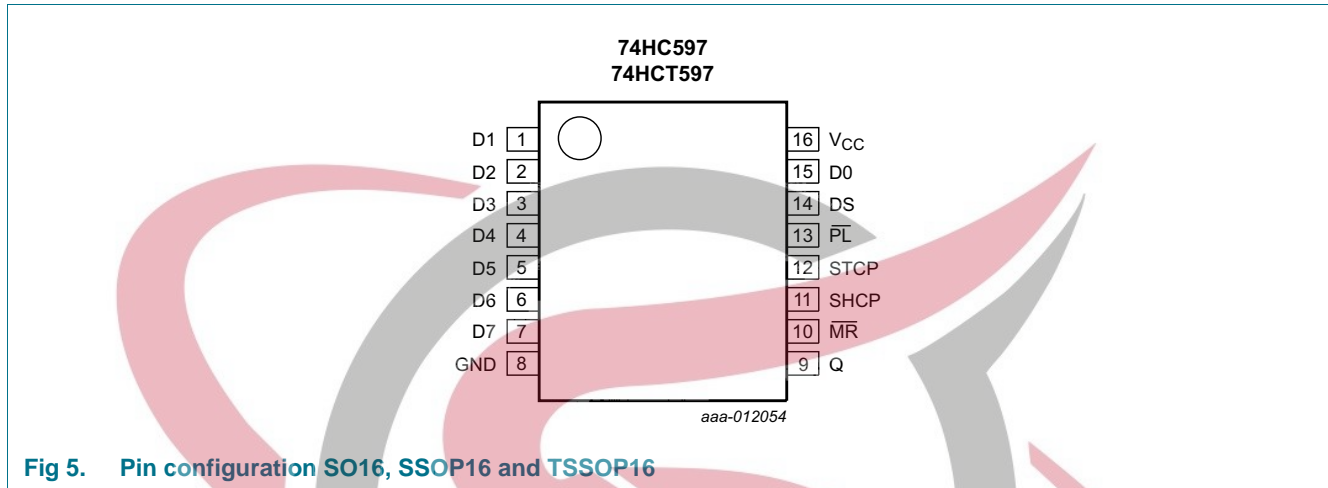

Fig 5. Pin configuration SO16, SSOP16 and TSSOP16

5.2 Pin description

Table 2. Pin description

Symbol	Pin	Description
GND	8	ground (0 V)
Q	9	serial data output
MR	10	asynchronous master reset input (active LOW)
SHCP	11	shift register clock input (LOW-to-HIGH, edge-triggered)
STCP	12	storage register clock input (LOW-to-HIGH, edge-triggered)
PL	13	parallel load input (active LOW)
DS	14	serial data input
D0, D1, D2, D3, D4, D5, D6, D7	15, 1, 2, 3, 4, 5, 6, 7	parallel data inputs
V _{CC}	16	supply voltage

6. Functional description

Table 3. Function table^[1]

Inputs				Function
STCP	SHCP	\overline{PL}	\overline{MR}	
↑	X	X	X	data loaded to input latches
↑	X	L	H	data loaded from inputs to shift register
no clock edge	X	L	H	data transferred from input flip-flops to shift register
X	X	L	L	invalid logic, state of shift register is indeterminate when signals removed
X	X	H	L	shift register cleared
X	↑	H	H	shift register clocked $Q_n = Q_{n-1}$, $Q_0 = DS$

- [1] H = HIGH voltage level.
- L = LOW voltage level.
- X = don't care.
- ↑ = positive-going transition.

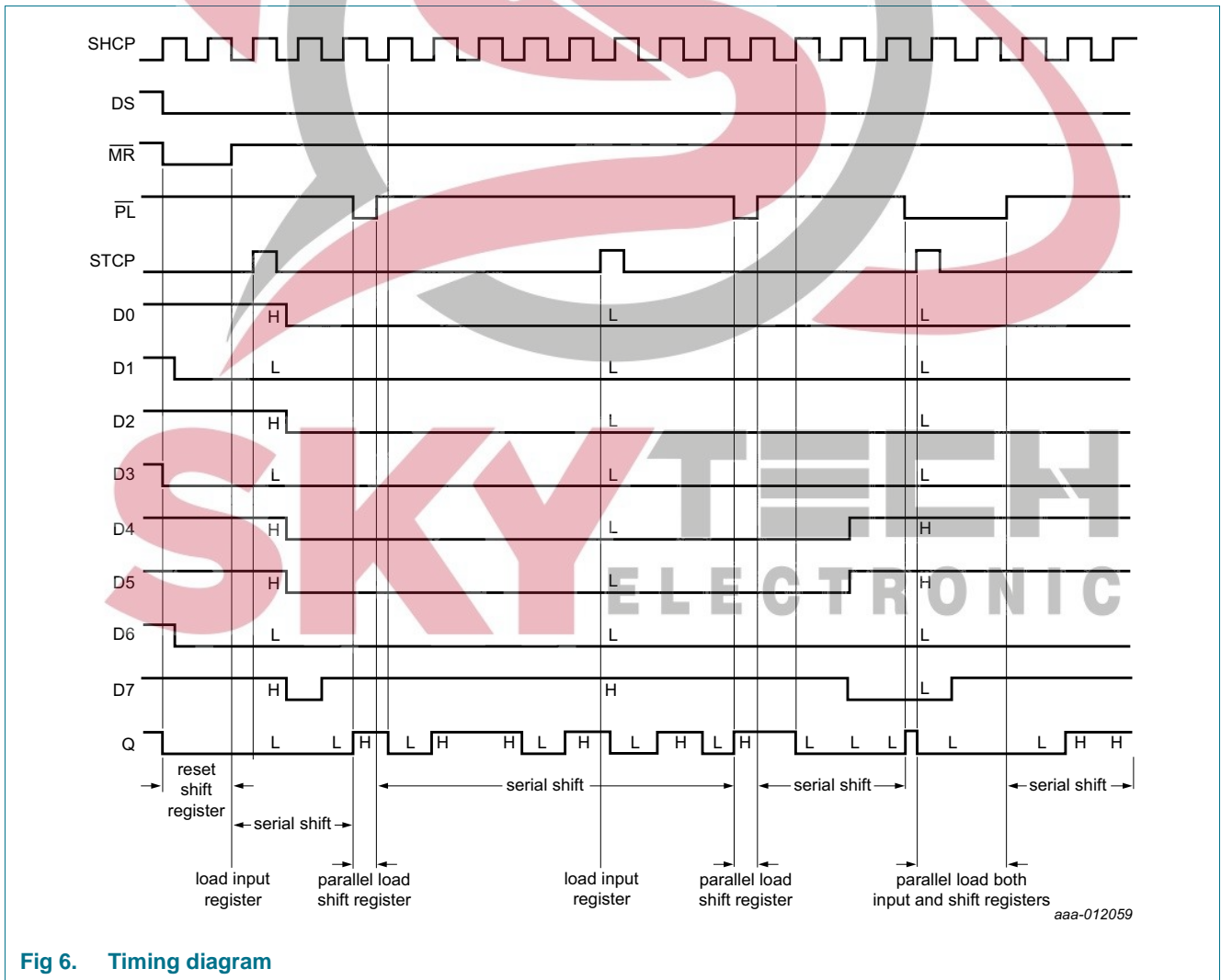

7. Limiting values

Table 4. Limiting values

In accordance with the Absolute Maximum Rating System (IEC 60134). Voltages are referenced to GND (ground = 0 V).

Symbol	Parameter	Conditions	Min	Max	Unit
V_{CC}	supply voltage		-0.5	+7	V
I_{IK}	input clamping current	$V_I < -0.5\text{ V}$ or $V_I > V_{CC} + 0.5\text{ V}$	-	± 20	mA
I_{OK}	output clamping current	$V_O < -0.5\text{ V}$ or $V_O > V_{CC} + 0.5\text{ V}$	-	± 20	mA
I_O	output current	$V_O = -0.5\text{ V}$ to $(V_{CC} + 0.5\text{ V})$	-	± 25	mA
I_{CC}	supply current		-	+50	mA
I_{GND}	ground current		-50	-	mA
T_{stg}	storage temperature		-65	+150	°C
P_{tot}	total power dissipation	SO16, SSOP16 and TSSOP16 packages [1]	-	500	mW

[1] For SO16 package: P_{tot} derates linearly with 8 mW/K above 70 °C.

For SSOP16 and TSSOP16 packages: P_{tot} derates linearly with 5.5 mW/K above 60 °C.

8. Recommended operating conditions

Table 5. Recommended operating conditions

Voltages are referenced to GND (ground = 0 V)

Symbol	Parameter	Conditions	74HC597			74HCT597			Unit
			Min	Typ	Max	Min	Typ	Max	
V_{CC}	supply voltage		2.0	5.0	6.0	4.5	5.0	5.5	V
V_I	input voltage		0	-	V_{CC}	0	-	V_{CC}	V
V_O	output voltage		0	-	V_{CC}	0	-	V_{CC}	V
T_{amb}	ambient temperature		-40	+25	+125	-40	+25	+125	°C
$\Delta t/\Delta V$	input transition rise and fall rate	$V_{CC} = 2.0\text{ V}$	-	-	625	-	-	-	ns/V
		$V_{CC} = 4.5\text{ V}$	-	1.67	139	-	1.67	139	ns/V
		$V_{CC} = 6.0\text{ V}$	-	-	83	-	-	-	ns/V

SKYTECH
ELECTRONIC

9. Static characteristics

Table 6. Static characteristics

At recommended operating conditions; voltages are referenced to GND (ground = 0 V).

Symbol	Parameter	Conditions	25 °C			-40 °C to +85 °C		-40 °C to +125 °C		Unit
			Min	Typ	Max	Min	Max	Min	Max	
74HC597										
V _{IH}	HIGH-level input voltage	V _{CC} = 2.0 V	1.5	1.2	-	1.5	-	1.5	-	V
		V _{CC} = 4.5 V	3.15	2.4	-	3.15	-	3.15	-	V
		V _{CC} = 6.0 V	4.2	3.2	-	4.2	-	4.2	-	V
V _{IL}	LOW-level input voltage	V _{CC} = 2.0 V	-	0.8	0.5	-	0.5	-	0.5	V
		V _{CC} = 4.5 V	-	2.1	1.35	-	1.35	-	1.35	V
		V _{CC} = 6.0 V	-	2.8	1.8	-	1.8	-	1.8	V
V _{OH}	HIGH-level output voltage	V _I = V _{IH} or V _{IL}								
		I _O = -20 μA; V _{CC} = 2.0 V	1.9	2.0	-	1.9	-	1.9	-	V
		I _O = -20 μA; V _{CC} = 4.5 V	4.4	4.5	-	4.4	-	4.4	-	V
		I _O = -20 μA; V _{CC} = 6.0 V	5.9	6.0	-	5.9	-	5.9	-	V
		I _O = -4.0 mA; V _{CC} = 4.5 V	3.98	4.32	-	3.84	-	3.7	-	V
		I _O = -5.2 mA; V _{CC} = 6.0 V	5.48	5.81	-	5.34	-	5.2	-	V
V _{OL}	LOW-level output voltage	V _I = V _{IH} or V _{IL}								
		I _O = 20 μA; V _{CC} = 2.0 V	-	0	0.1	-	0.1	-	0.1	V
		I _O = 20 μA; V _{CC} = 4.5 V	-	0	0.1	-	0.1	-	0.1	V
		I _O = 20 μA; V _{CC} = 6.0 V	-	0	0.1	-	0.1	-	0.1	V
		I _O = 4.0 mA; V _{CC} = 4.5 V	-	0.15	0.26	-	0.33	-	0.4	V
		I _O = 5.2 mA; V _{CC} = 6.0 V	-	0.16	0.26	-	0.33	-	0.4	V
I _I	input leakage current	V _I = V _{CC} or GND; V _{CC} = 6.0 V	-	-	±0.1	-	±1.0	-	±1.0	μA
I _{CC}	supply current	V _I = V _{CC} or GND; I _O = 0 A; V _{CC} = 6.0 V	-	-	8.0	-	80.0	-	160.0	μA
C _I	input capacitance		-	3.5	-	-	-	-	-	pF
74HCT597										
V _{IH}	HIGH-level input voltage	V _{CC} = 4.5 V to 5.5 V	2.0	1.6	-	2.0	-	2.0	-	V
V _{IL}	LOW-level input voltage	V _{CC} = 4.5 V to 5.5 V	-	1.2	0.8	-	0.8	-	0.8	V
V _{OH}	HIGH-level output voltage	V _I = V _{IH} or V _{IL} ; V _{CC} = 4.5 V								
		I _O = -20 μA	4.4	4.5	-	4.4	-	4.4	-	V
		I _O = -4.0 mA	3.98	4.32	-	3.84	-	3.7	-	V
V _{OL}	LOW-level output voltage	V _I = V _{IH} or V _{IL} ; V _{CC} = 4.5 V								
		I _O = 20 μA	-	0	0.1	-	0.1	-	0.1	V
		I _O = 4.0 mA	-	0.15	0.26	-	0.33	-	0.4	V
I _I	input leakage current	V _I = V _{CC} or GND; V _{CC} = 5.5 V	-	-	±0.1	-	±1.0	-	±1.0	μA

Table 6. Static characteristics ...continued

At recommended operating conditions; voltages are referenced to GND (ground = 0 V).

Symbol	Parameter	Conditions	25 °C			-40 °C to +85 °C		-40 °C to +125 °C		Unit
			Min	Typ	Max	Min	Max	Min	Max	
I_{CC}	supply current	$V_I = V_{CC}$ or GND; $I_O = 0$ A; $V_{CC} = 5.5$ V	-	-	8.0	-	80.0	-	160.0	μ A
ΔI_{CC}	additional supply current	$V_I = V_{CC} - 2.1$ V; other inputs at V_{CC} or GND; $V_{CC} = 4.5$ V to 5.5 V; $I_O = 0$ A								
		per input pin; DS input	-	25	90	-	112.5	-	122.5	μ A
		per input pin; Dn inputs	-	30	108	-	135	-	147	μ A
		per input pin; \overline{PL} , MR inputs	-	150	540	-	675	-	735	μ A
		per input pin; STCP, SHCP inputs	-	150	540	-	675	-	735	μ A
C_I	input capacitance		-	3.5	-	-	-	-	-	pF

10. Dynamic characteristics

Table 7. Dynamic characteristicsVoltages are referenced to GND (ground = 0 V); $C_L = 50$ pF unless otherwise specified; for test circuit, see [Figure 13](#).

Symbol	Parameter	Conditions	25 °C			-40 °C to +85 °C		-40 °C to +125 °C		Unit
			Min	Typ	Max	Min	Max	Min	Max	
74HC597										
t_{pd}	propagation delay	SHCP to Q; see Figure 7 ^[1]								
		$V_{CC} = 2.0$ V	-	55	175	-	220	-	265	ns
		$V_{CC} = 4.5$ V	-	20	35	-	44	-	53	ns
		$V_{CC} = 5.0$ V; $C_L = 15$ pF	-	17	-	-	-	-	-	ns
		$V_{CC} = 6.0$ V	-	16	30	-	37	-	45	ns
		\overline{MR} to Q; see Figure 8 ^[1]								
		$V_{CC} = 2.0$ V	-	58	175	-	220	-	265	ns
		$V_{CC} = 4.5$ V	-	21	35	-	44	-	53	ns
		$V_{CC} = 6.0$ V	-	17	30	-	37	-	45	ns
		STCP to Q; see Figure 7 ^[1]								
		$V_{CC} = 2.0$ V	-	80	250	-	315	-	375	ns
		$V_{CC} = 4.5$ V	-	29	50	-	63	-	75	ns
		$V_{CC} = 5.0$ V; $C_L = 15$ pF	-	25	-	-	-	-	-	ns
		$V_{CC} = 6.0$ V	-	23	43	-	54	-	64	ns
		\overline{PL} to Q; see Figure 9 ^[1]								
		$V_{CC} = 2.0$ V	-	69	215	-	270	-	325	ns
$V_{CC} = 4.5$ V	-	25	43	-	54	-	65	ns		
$V_{CC} = 5.0$ V; $C_L = 15$ pF	-	21	-	-	-	-	-	ns		
$V_{CC} = 6.0$ V	-	20	37	-	46	-	55	ns		

Table 7. Dynamic characteristics ...continued

Voltages are referenced to GND (ground = 0 V); $C_L = 50$ pF unless otherwise specified; for test circuit, see [Figure 13](#).

Symbol	Parameter	Conditions	25 °C			–40 °C to +85 °C		–40 °C to +125 °C		Unit
			Min	Typ	Max	Min	Max	Min	Max	
t_t	transition time	see Figure 9 [2]								
		$V_{CC} = 2.0$ V	-	19	75	-	95	-	110	ns
		$V_{CC} = 4.5$ V	-	7	15	-	19	-	22	ns
		$V_{CC} = 6.0$ V	-	6	13	-	16	-	19	ns
t_w	pulse width	STCP HIGH or LOW; see Figure 7								
		$V_{CC} = 2.0$ V	80	11	-	100	-	120	-	ns
		$V_{CC} = 4.5$ V	16	4	-	20	-	24	-	ns
		$V_{CC} = 6.0$ V	14	3	-	17	-	20	-	ns
		SHCP HIGH or LOW; see Figure 7								
		$V_{CC} = 2.0$ V	80	14	-	100	-	120	-	ns
		$V_{CC} = 4.5$ V	16	5	-	20	-	24	-	ns
		$V_{CC} = 6.0$ V	14	4	-	17	-	20	-	ns
		MR LOW; see Figure 8								
		$V_{CC} = 2.0$ V	80	22	-	100	-	120	-	ns
		$V_{CC} = 4.5$ V	16	8	-	20	-	24	-	ns
		$V_{CC} = 6.0$ V	14	6	-	17	-	20	-	ns
		PL LOW; see Figure 9								
		$V_{CC} = 2.0$ V	80	22	-	100	-	120	-	ns
		$V_{CC} = 4.5$ V	16	8	-	20	-	24	-	ns
		$V_{CC} = 6.0$ V	14	6	-	17	-	20	-	ns
t_{rec}	recovery time	MR to SHCP; see Figure 10								
		$V_{CC} = 2.0$ V	60	-3	-	75	-	90	-	ns
		$V_{CC} = 4.5$ V	12	-1	-	15	-	18	-	ns
		$V_{CC} = 6.0$ V	10	-1	-	13	-	15	-	ns

SKY
TECH
ELECTRONIC

Table 7. Dynamic characteristics ...continued

Voltages are referenced to GND (ground = 0 V); $C_L = 50$ pF unless otherwise specified; for test circuit, see [Figure 13](#).

Symbol	Parameter	Conditions	25 °C			–40 °C to +85 °C		–40 °C to +125 °C		Unit
			Min	Typ	Max	Min	Max	Min	Max	
t_{su}	set-up time	Dn to STCP; see Figure 11								
		$V_{CC} = 2.0$ V	60	8	-	75	-	90	-	ns
		$V_{CC} = 4.5$ V	12	3	-	15	-	18	-	ns
		$V_{CC} = 6.0$ V	10	2	-	13	-	15	-	ns
		DS to SHCP; see Figure 11								
		$V_{CC} = 2.0$ V	60	11	-	75	-	90	-	ns
		$V_{CC} = 4.5$ V	12	4	-	15	-	18	-	ns
		$V_{CC} = 6.0$ V	10	3	-	13	-	15	-	ns
		PL to SHCP; see Figure 12								
		$V_{CC} = 2.0$ V	60	11	-	75	-	90	-	ns
$V_{CC} = 4.5$ V	12	4	-	15	-	18	-	ns		
$V_{CC} = 6.0$ V	10	3	-	13	-	15	-	ns		
t_h	hold time	Dn to STCP; see Figure 11								
		$V_{CC} = 2.0$ V	5	-3	-	5	-	5	-	ns
		$V_{CC} = 4.5$ V	5	-1	-	5	-	5	-	ns
		$V_{CC} = 6.0$ V	5	-1	-	5	-	5	-	ns
		PL, DS to SHCP; see Figure 11								
		$V_{CC} = 2.0$ V	5	-6	-	5	-	5	-	ns
		$V_{CC} = 4.5$ V	5	-2	-	5	-	5	-	ns
$V_{CC} = 6.0$ V	5	-2	-	5	-	5	-	ns		
f_{max}	maximum frequency	SHCP; see Figure 7								
		$V_{CC} = 2.0$ V	6.0	29	-	4.8	-	4.0	-	MHz
		$V_{CC} = 4.5$ V	30	87	-	24	-	20	-	MHz
		$V_{CC} = 5.0$ V; $C_L = 15$ pF	-	96	-	-	-	-	-	MHz
$V_{CC} = 6.0$ V	35	104	-	28	-	24	-	MHz		
C_{PD}	power dissipation capacitance	$C_L = 50$ pF; $f = 1$ MHz; $V_1 = \text{GND to } V_{CC}$	[3]	-	29	-	-	-	-	pF

Table 7. Dynamic characteristics ...continued

Voltages are referenced to GND (ground = 0 V); $C_L = 50$ pF unless otherwise specified; for test circuit, see [Figure 13](#).

Symbol	Parameter	Conditions	25 °C			−40 °C to +85 °C		−40 °C to +125 °C		Unit
			Min	Typ	Max	Min	Max	Min	Max	
74HCT597										
t_{pd}	propagation delay	SHCP to Q; see Figure 7 ^[1]								
		$V_{CC} = 4.5$ V	-	23	40	-	50	-	60	ns
		$V_{CC} = 5.0$ V; $C_L = 15$ pF	-	20	-	-	-	-	-	ns
		\overline{MR} to Q; see Figure 8 ^[1]								
		$V_{CC} = 4.5$ V	-	28	49	-	61	-	74	ns
		STCP to Q; see Figure 7 ^[1]								
		$V_{CC} = 4.5$ V	-	33	57	-	71	-	86	ns
		$V_{CC} = 5.0$ V; $C_L = 15$ pF	-	29	-	-	-	-	-	ns
t_t	transition time	PL to Q; see Figure 9 ^[1]								
		$V_{CC} = 4.5$ V	-	30	52	-	65	-	78	ns
t_t	transition time	$V_{CC} = 5.0$ V; $C_L = 15$ pF	-	26	-	-	-	-	-	ns
		see Figure 7 ^[2]								
t_t	transition time	$V_{CC} = 4.5$ V	-	7	15	-	19	-	22	ns
		t_w	pulse width	STCP HIGH or LOW; see Figure 7						
$V_{CC} = 4.5$ V	16			6	-	20	-	24	-	ns
SHCP HIGH or LOW; see Figure 7										
$V_{CC} = 4.5$ V	16			7	-	20	-	24	-	ns
MR LOW; see Figure 8										
$V_{CC} = 4.5$ V	25			14	-	31	-	38	-	ns
t_w	pulse width	PL LOW; see Figure 9								
		$V_{CC} = 4.5$ V	20	10	-	25	-	30	-	ns
t_{rec}	recovery time	MR to SHCP; see Figure 10								
		$V_{CC} = 4.5$ V	12	-2	-	15	-	18	-	ns
t_{su}	set-up time	Dn to STCP; see Figure 11								
		$V_{CC} = 4.5$ V	12	5	-	15	-	18	-	ns
		DS to SHCP; see Figure 11								
		$V_{CC} = 4.5$ V	12	2	-	15	-	18	-	ns
		PL to SHCP; see Figure 12								
t_{su}	set-up time	$V_{CC} = 4.5$ V	12	4	-	15	-	18	-	ns

Table 7. Dynamic characteristics ...continued

Voltages are referenced to GND (ground = 0 V); $C_L = 50$ pF unless otherwise specified; for test circuit, see [Figure 13](#).

Symbol	Parameter	Conditions	25 °C			-40 °C to +85 °C		-40 °C to +125 °C		Unit
			Min	Typ	Max	Min	Max	Min	Max	
t_h	hold time	Dn to STCP; see Figure 11								
		$V_{CC} = 4.5$ V	5	-1	-	5	-	5	-	ns
		PL, DS to SHCP; see Figure 11								
f_{max}	maximum frequency	$V_{CC} = 4.5$ V	5	-2	-	5	-	5	-	ns
		SHCP; see Figure 7								
		$V_{CC} = 5.0$ V; $C_L = 15$ pF	30	75	-	24	-	20	-	MHz
C_{PD}	power dissipation capacitance	$C_L = 50$ pF; $f = 1$ MHz; $V_I = GND$ to $V_{CC} - 1.5$ V	-	32	-	-	-	-	-	pF

- [1] t_{pd} is the same as t_{PLH} and t_{PHL} .
- [2] t_t is the same as t_{THL} and t_{TLH} .
- [3] C_{PD} is used to determine the dynamic power dissipation (P_D in μ W).
 $P_D = C_{PD} \times V_{CC}^2 \times f_i \times N + \sum(C_L \times V_{CC}^2 \times f_o)$ where:
 f_i = input frequency in MHz;
 f_o = output frequency in MHz;
 C_L = output load capacitance in pF;
 V_{CC} = supply voltage in V;
 N = number of inputs switching;
 $\sum(C_L \times V_{CC}^2 \times f_o)$ = sum of outputs.

11. Waveforms

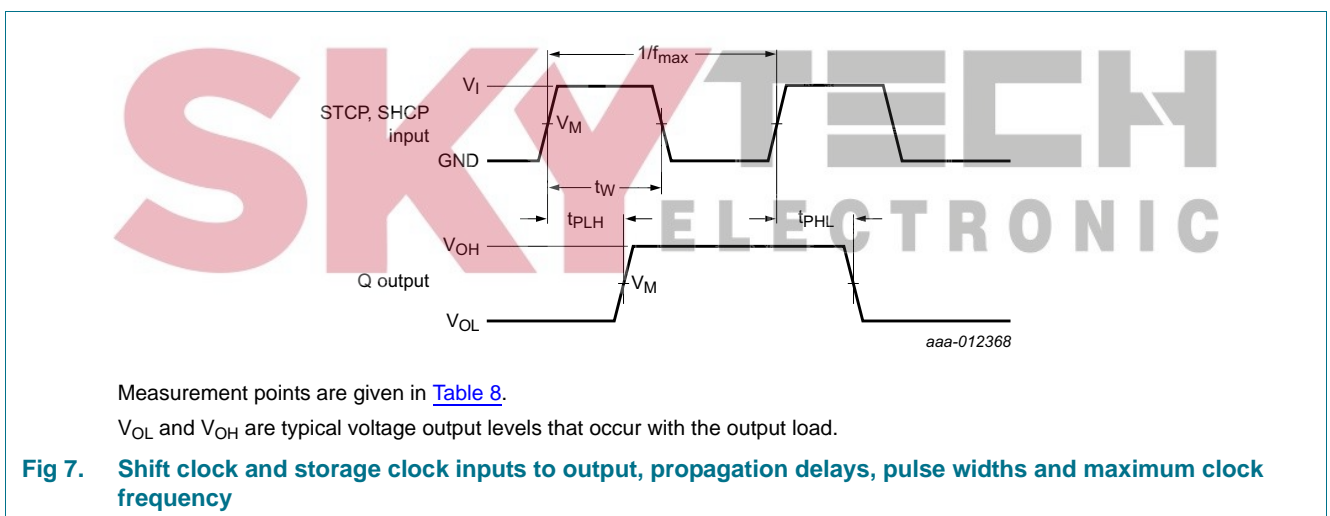

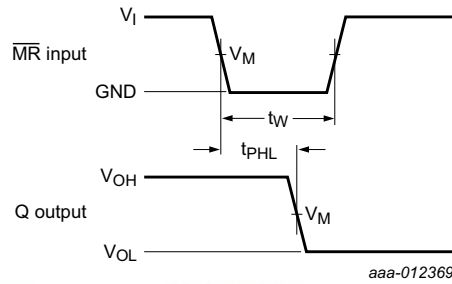

Measurement points are given in [Table 8](#).
 V_{OL} and V_{OH} are typical voltage output levels that occur with the output load.

Fig 8. Input (\overline{MR}) to (Q), output propagation delays and (\overline{MR}) pulse width

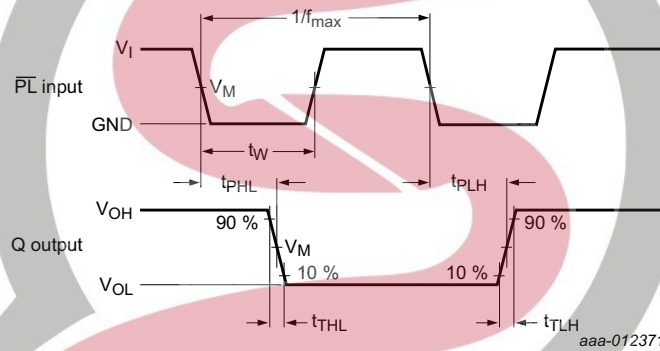

Measurement points are given in [Table 8](#).
 V_{OL} and V_{OH} are typical voltage output levels that occur with the output load.

Fig 9. Input (\overline{PL}) to (Q), output propagation delays, \overline{PL} pulse width and output transition times

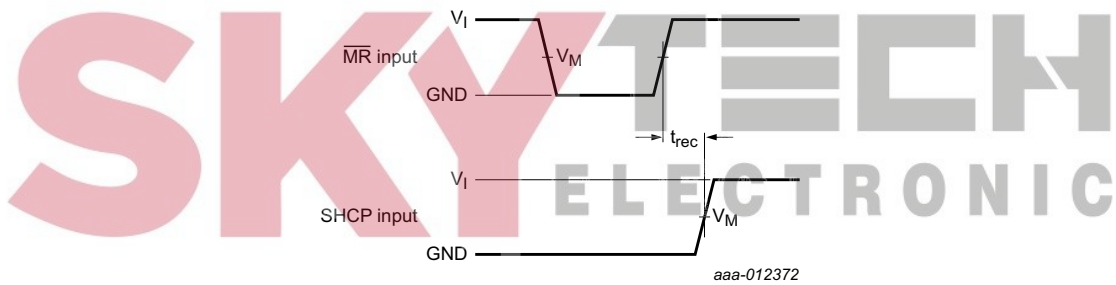

Measurement points are given in [Table 8](#).

Fig 10. Input (\overline{MR}) to shift clock (SHCP) and storage clock (STCP) recovery times

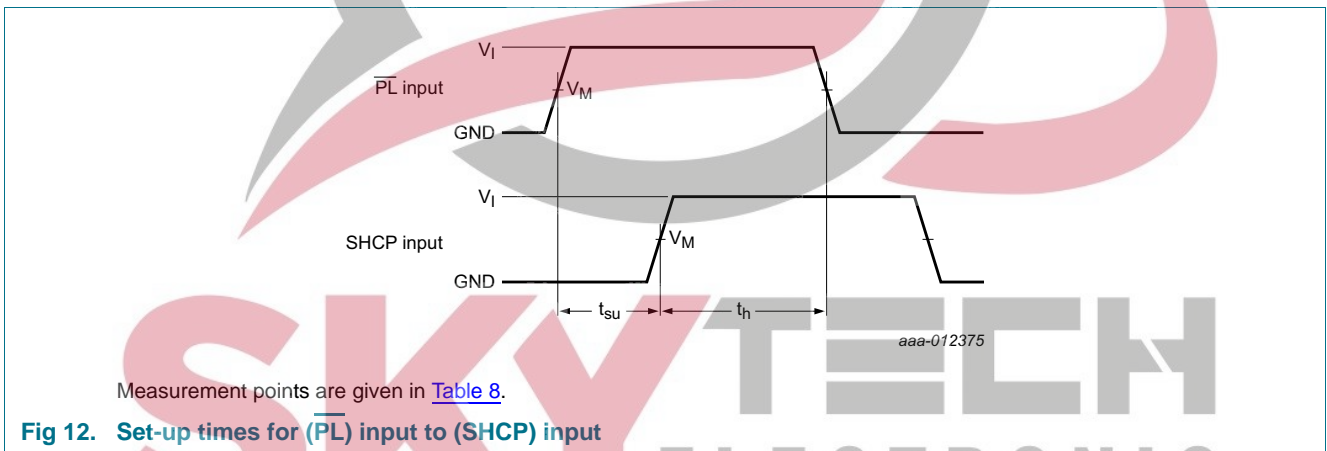
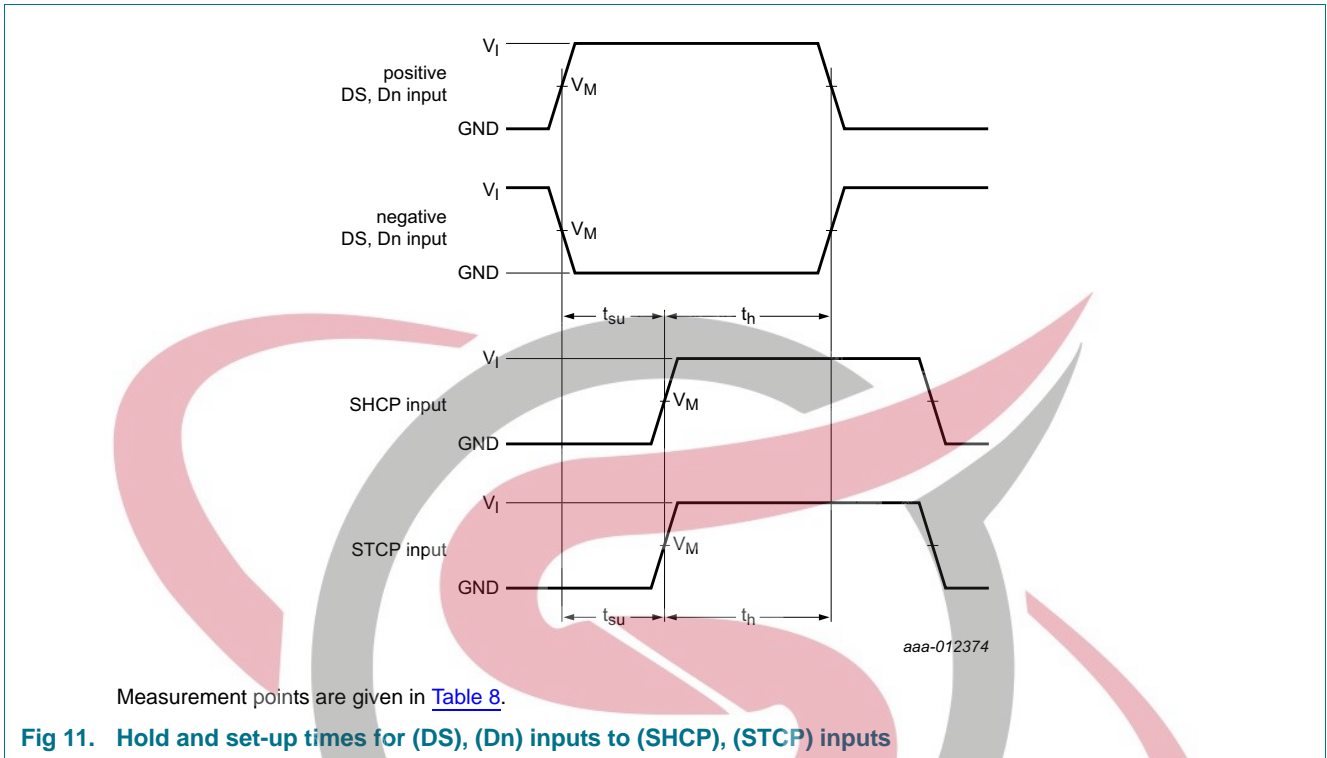

Table 8. Measurement points

Type	Input	V_I	Output
	V_M		V_M
74HC597	$0.5 \times V_{CC}$	GND to V_{CC}	$0.5 \times V_{CC}$
74HCT597	1.3 V	GND to 3 V	1.3 V

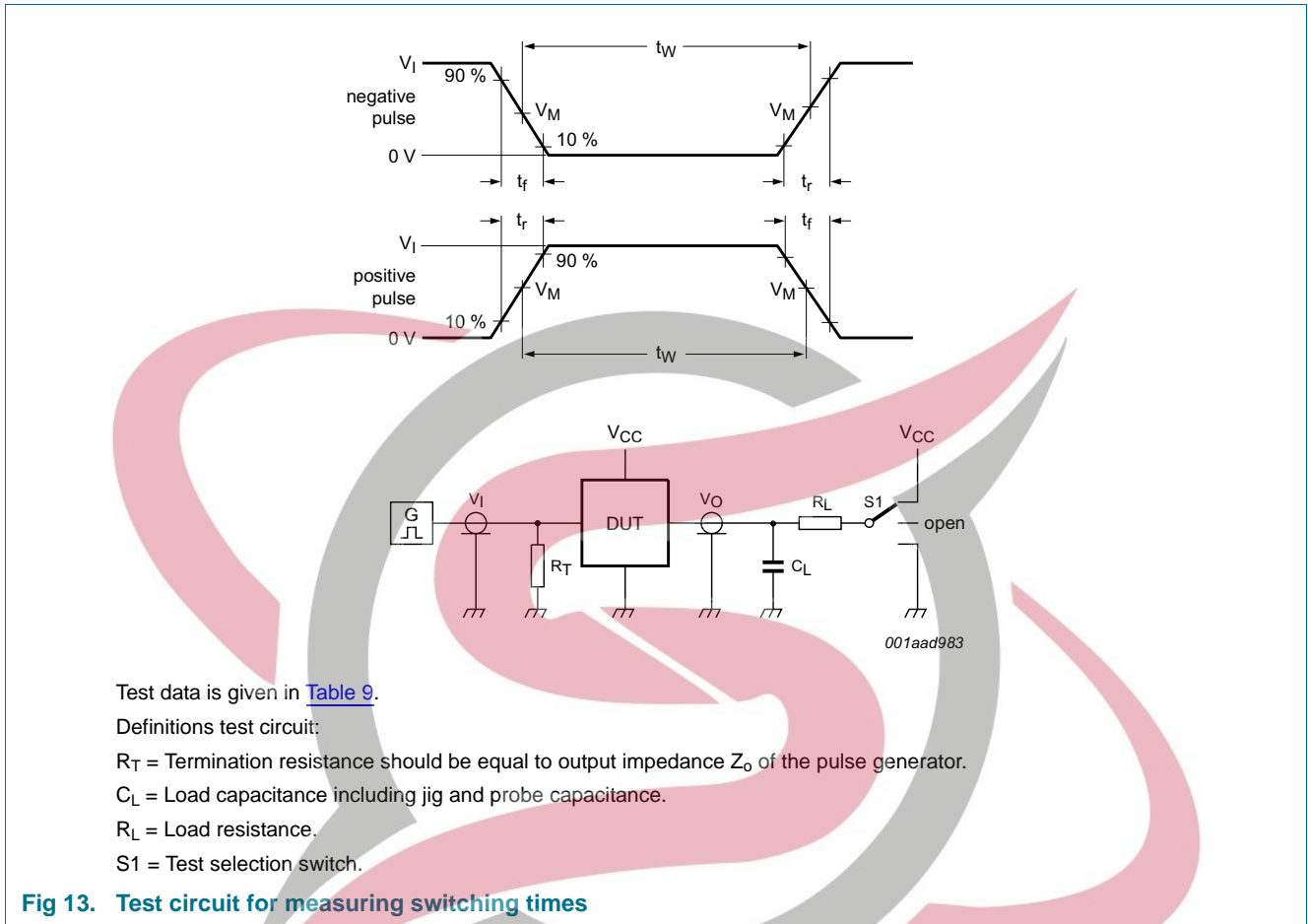

Fig 13. Test circuit for measuring switching times

Table 9. Test data

Type	Input		Load		S1 position		
	V_I	t_r, t_f	C_L	R_L	t_{PHL}, t_{PLH}	t_{PZH}, t_{PHZ}	t_{PZL}, t_{PLZ}
74HC597	V_{CC}	6 ns	15 pF, 50 pF	1 k Ω	open	GND	V_{CC}
74HCT597	3 V	6 ns	15 pF, 50 pF	1 k Ω	open	GND	V_{CC}

12. Package outline

SO16: plastic small outline package; 16 leads; body width 3.9 mm

SOT109-1

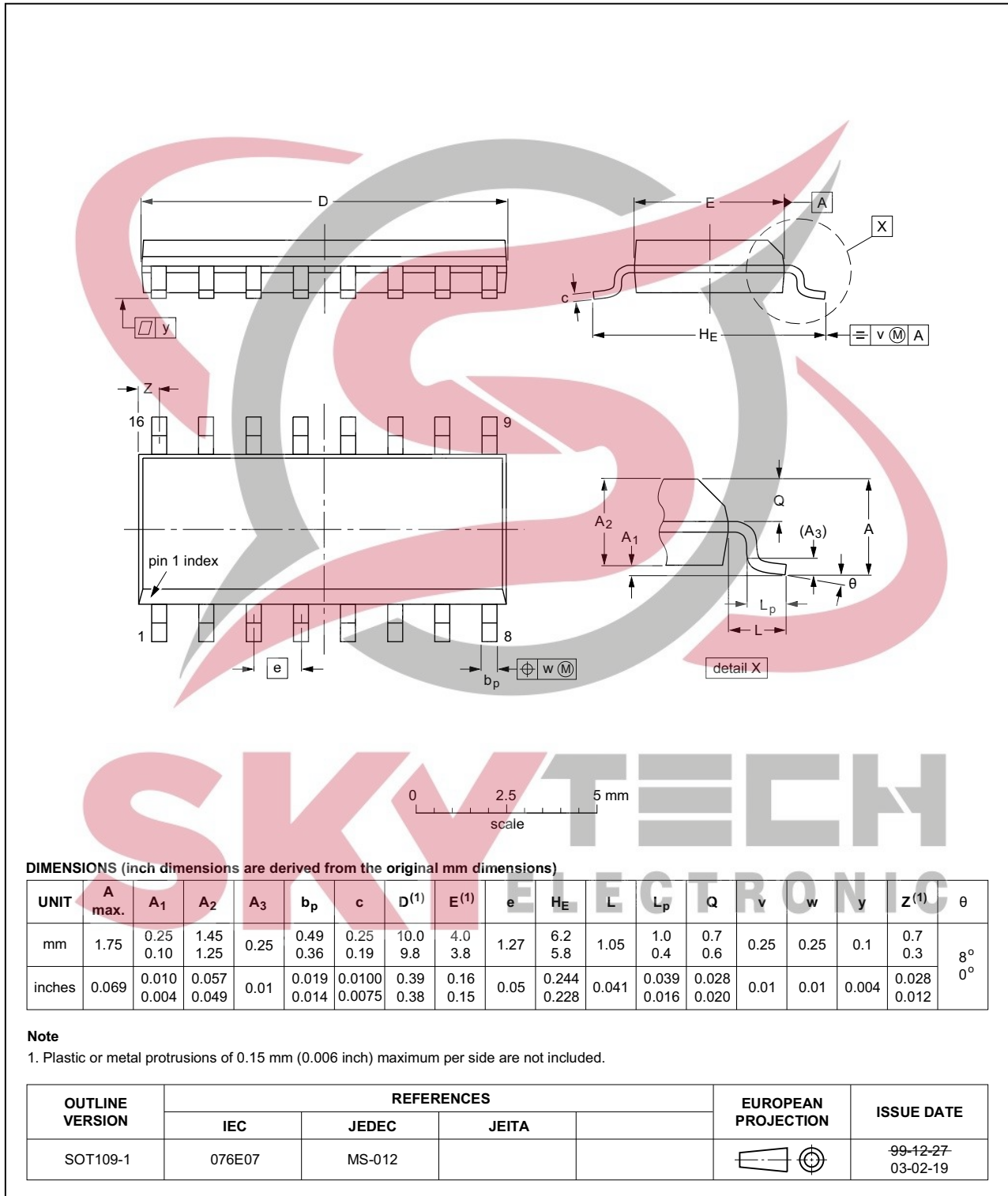

Fig 14. Package outline SOT109-1 (SO16)

SSOP16: plastic shrink small outline package; 16 leads; body width 5.3 mm

SOT338-1

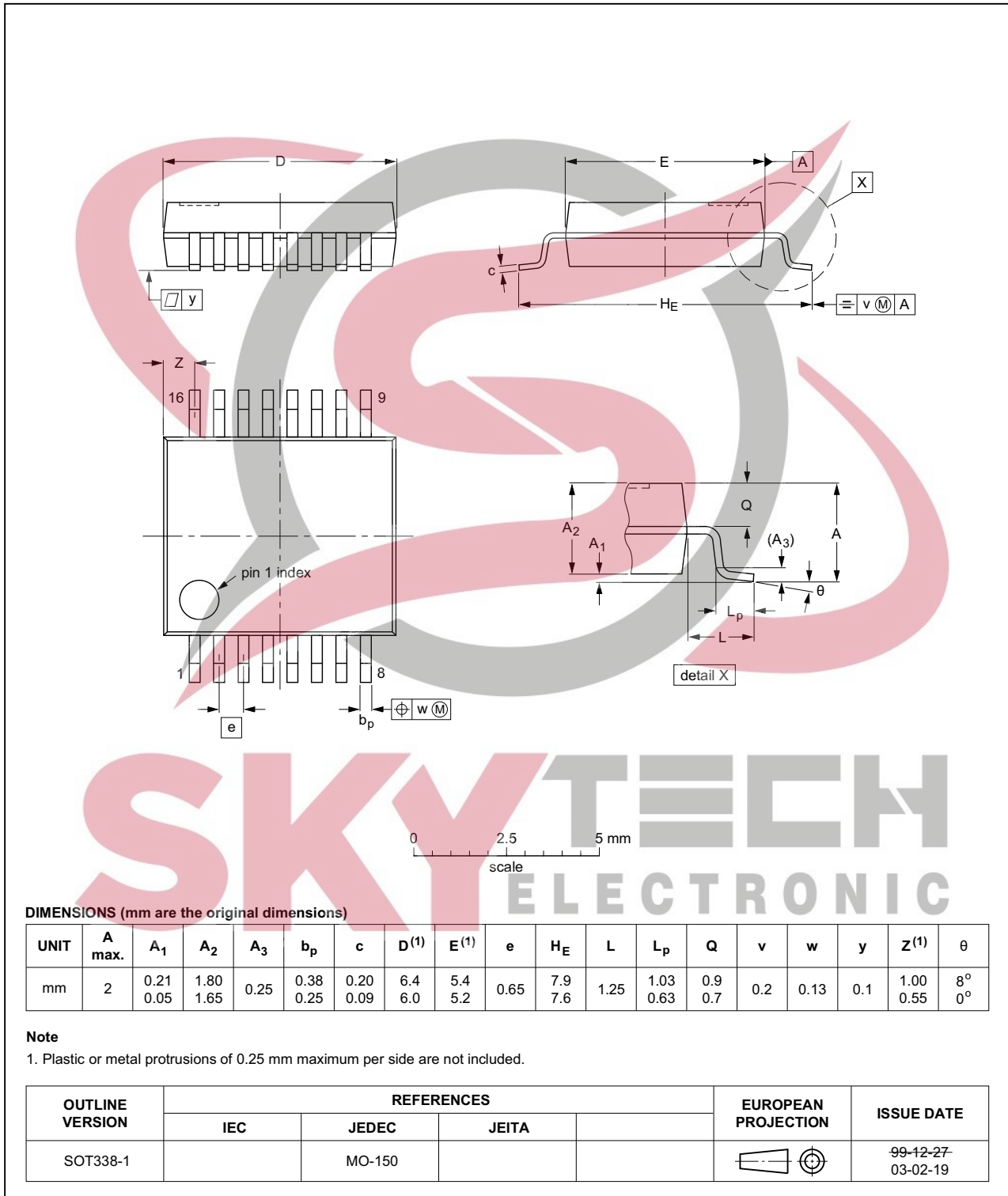

Fig 15. Package outline SOT338-1 (SSOP16)

TSSOP16: plastic thin shrink small outline package; 16 leads; body width 4.4 mm

SOT403-1

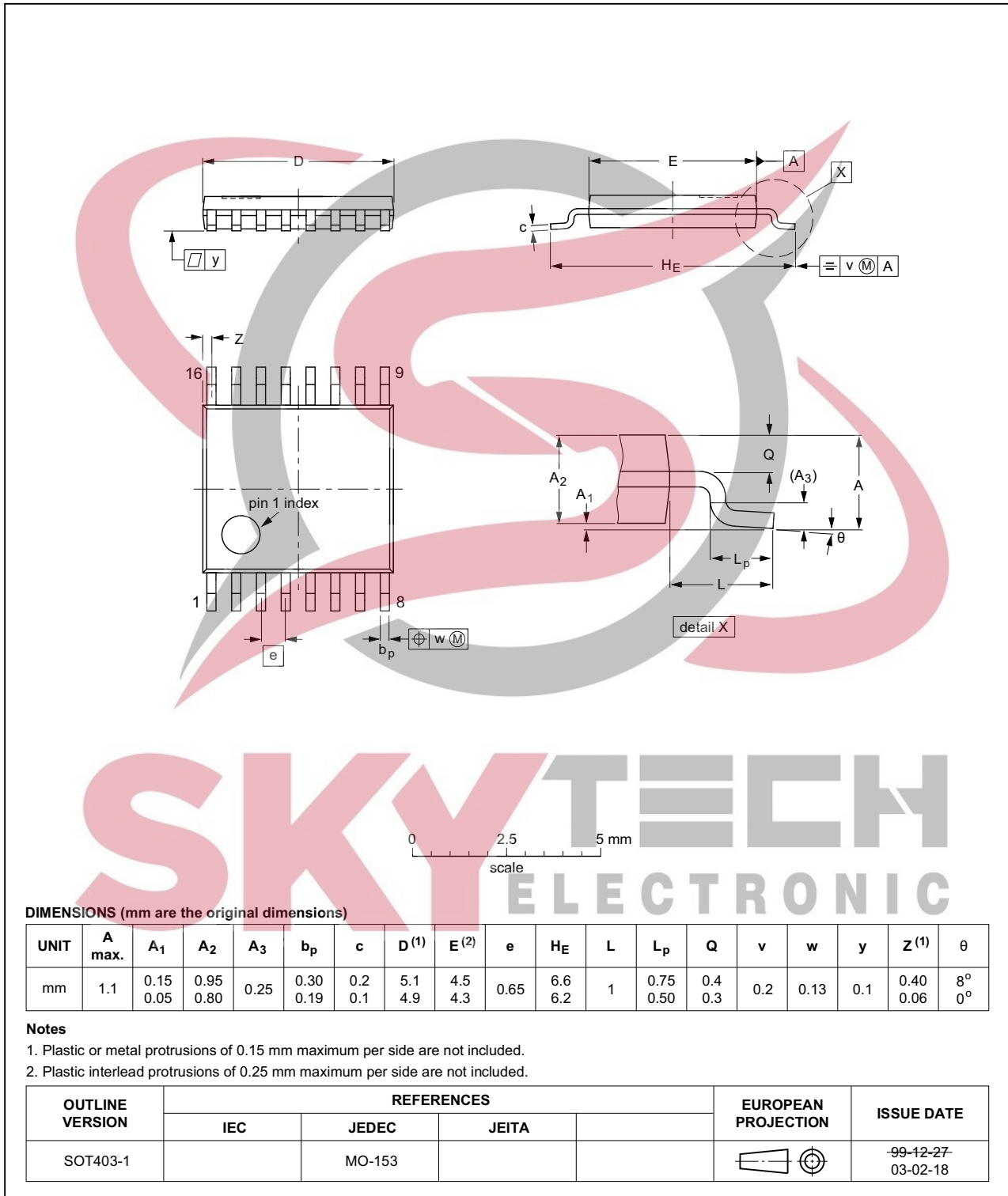

Fig 16. Package outline SOT403-1 (TSSOP16)

13. Abbreviations

Table 10. Abbreviations

Acronym	Description
CMOS	Complementary Metal Oxide Semiconductor
DUT	Device Under Test
ESD	ElectroStatic Discharge
HBM	Human Body Model
MM	Machine Model
TTL	Transistor-Transistor Logic

14. Revision history

Table 11. Revision history

Document ID	Release date	Data sheet status	Change notice	Supersedes
74HC_HCT597 v.4	20160225	Product data sheet	-	74HC_HCT597 v.3
Modifications:	<ul style="list-style-type: none"> Type numbers 74HC597N and 74HCT597N (SOT38-4) removed. 			
74HC_HCT597 v.3	20140415	Product data sheet	-	74HC_HCT597_CNV v.2
Modifications:	<ul style="list-style-type: none"> The format of this data sheet has been redesigned to comply with the new identity guidelines of NXP Semiconductors. Legal texts have been adapted to the new company name where appropriate. 			
74HC_HCT597_CNV v.2	19901201	Product specification	-	-



SKYTECH
ELECTRONIC

15. Legal information

15.1 Data sheet status

Document status ^{[1][2]}	Product status ^[3]	Definition
Objective [short] data sheet	Development	This document contains data from the objective specification for product development.
Preliminary [short] data sheet	Qualification	This document contains data from the preliminary specification.
Product [short] data sheet	Production	This document contains the product specification.

[1] Please consult the most recently issued document before initiating or completing a design.

[2] The term 'short data sheet' is explained in section "Definitions".

[3] The product status of device(s) described in this document may have changed since this document was published and may differ in case of multiple devices. The latest product status information is available on the Internet at URL <http://www.nexperia.com>.

15.2 Definitions

Draft — The document is a draft version only. The content is still under internal review and subject to formal approval, which may result in modifications or additions. Nexperia does not give any representations or warranties as to the accuracy or completeness of information included herein and shall have no liability for the consequences of use of such information.

Short data sheet — A short data sheet is an extract from a full data sheet with the same product type number(s) and title. A short data sheet is intended for quick reference only and should not be relied upon to contain detailed and full information. For detailed and full information see the relevant full data sheet, which is available on request via the local Nexperia sales office. In case of any inconsistency or conflict with the short data sheet, the full data sheet shall prevail.

Product specification — The information and data provided in a Product data sheet shall define the specification of the product as agreed between Nexperia and its customer, unless Nexperia and customer have explicitly agreed otherwise in writing. In no event however, shall an agreement be valid in which the Nexperia product is deemed to offer functions and qualities beyond those described in the Product data sheet.

Suitability for use — Nexperia products are not designed, authorized or warranted to be suitable for use in life support, life-critical or safety-critical systems or equipment, nor in applications where failure or malfunction of a Nexperia product can reasonably be expected to result in personal injury, death or severe property or environmental damage. Nexperia and its suppliers accept no liability for inclusion and/or use of Nexperia products in such equipment or applications and therefore such inclusion and/or use is at the customer's own risk.

Applications — Applications that are described herein for any of these products are for illustrative purposes only. Nexperia makes no representation or warranty that such applications will be suitable for the specified use without further testing or modification.

Customers are responsible for the design and operation of their applications and products using Nexperia products, and Nexperia accepts no liability for any assistance with applications or customer product design. It is customer's sole responsibility to determine whether the Nexperia product is suitable and fit for the customer's applications and products planned, as well as for the planned application and use of customer's third party customer(s). Customers should provide appropriate design and operating safeguards to minimize the risks associated with their applications and products.

Nexperia does not accept any liability related to any default, damage, costs or problem which is based on any weakness or default in the customer's applications or products, or the application or use by customer's third party customer(s). Customer is responsible for doing all necessary testing for the customer's applications and products using Nexperia products in order to avoid a default of the applications and the products or of the application or use by customer's third party customer(s). Nexperia does not accept any liability in this respect.

Limiting values — Stress above one or more limiting values (as defined in the Absolute Maximum Ratings System of IEC 60134) will cause permanent damage to the device. Limiting values are stress ratings only and (proper) operation of the device at these or any other conditions above those given in the Recommended operating conditions section (if present) or the Characteristics sections of this document is not warranted. Constant or repeated exposure to limiting values will permanently and irreversibly affect the quality and reliability of the device.

Terms and conditions of commercial sale — Nexperia products are sold subject to the general terms and conditions of commercial sale, as published at <http://www.nexperia.com/profile/terms>, unless otherwise agreed in a valid written individual agreement. In case an individual agreement is concluded only the terms and conditions of the respective agreement shall apply. Nexperia hereby expressly objects to applying the customer's general terms and conditions with regard to the purchase of Nexperia products by customer.

No offer to sell or license — Nothing in this document may be interpreted or construed as an offer to sell products that is open for acceptance or the grant, conveyance or implication of any license under any copyrights, patents or other industrial or intellectual property rights.

15.3 Disclaimers

Limited warranty and liability — Information in this document is believed to be accurate and reliable. However, Nexperia does not give any representations or warranties, expressed or implied, as to the accuracy or completeness of such information and shall have no liability for the consequences of use of such information. Nexperia takes no responsibility for the content in this document if provided by an information source outside of Nexperia.

In no event shall Nexperia be liable for any indirect, incidental, punitive, special or consequential damages (including - without limitation - lost profits, lost savings, business interruption, costs related to the removal or replacement of any products or rework charges) whether or not such damages are based on tort (including negligence), warranty, breach of contract or any other legal theory.

Notwithstanding any damages that customer might incur for any reason whatsoever, Nexperia's aggregate and cumulative liability towards customer for the products described herein shall be limited in accordance with the *Terms and conditions of commercial sale* of Nexperia.

Right to make changes — Nexperia reserves the right to make changes to information published in this document, including without limitation specifications and product descriptions, at any time and without notice. This document supersedes and replaces all information supplied prior to the publication hereof.

Export control — This document as well as the item(s) described herein may be subject to export control regulations. Export might require a prior authorization from competent authorities.

Non-automotive qualified products — Unless this data sheet expressly states that this specific Nexperia product is automotive qualified, the product is not suitable for automotive use. It is neither qualified nor tested in accordance with automotive testing or application requirements. Nexperia accepts no liability for inclusion and/or use of non-automotive qualified products in automotive equipment or applications.

In the event that customer uses the product for design-in and use in automotive applications to automotive specifications and standards, customer (a) shall use the product without Nexperia's warranty of the product for such automotive applications, use and specifications, and (b) whenever customer uses the product for automotive applications beyond

Nexperia's specifications such use shall be solely at customer's own risk, and (c) customer fully indemnifies Nexperia for any liability, damages or failed product claims resulting from customer design and use of the product for automotive applications beyond Nexperia's standard warranty and Nexperia's product specifications.

Translations — A non-English (translated) version of a document is for reference only. The English version shall prevail in case of any discrepancy between the translated and English versions.

15.4 Trademarks

Notice: All referenced brands, product names, service names and trademarks are the property of their respective owners.

16. Contact information

For more information, please visit: <http://www.nexperia.com>

For sales office addresses, please send an email to: salesaddresses@nexperia.com



17. Contents

1	General description	1
2	Features and benefits	1
3	Ordering information	1
4	Functional diagram	2
5	Pinning information	4
5.1	Pinning	4
5.2	Pin description	4
6	Functional description	5
7	Limiting values	6
8	Recommended operating conditions	6
9	Static characteristics	7
10	Dynamic characteristics	8
11	Waveforms	12
12	Package outline	16
13	Abbreviations	19
14	Revision history	19
15	Legal information	20
15.1	Data sheet status	20
15.2	Definitions	20
15.3	Disclaimers	20
15.4	Trademarks	21
16	Contact information	21
17	Contents	22

